

S4812

2020-UP SUBARU OUTBACK XT/WILDERNESS,
2.4L TURBO, AXLE-BACK, 2.5" DUAL REAR

MBRP®

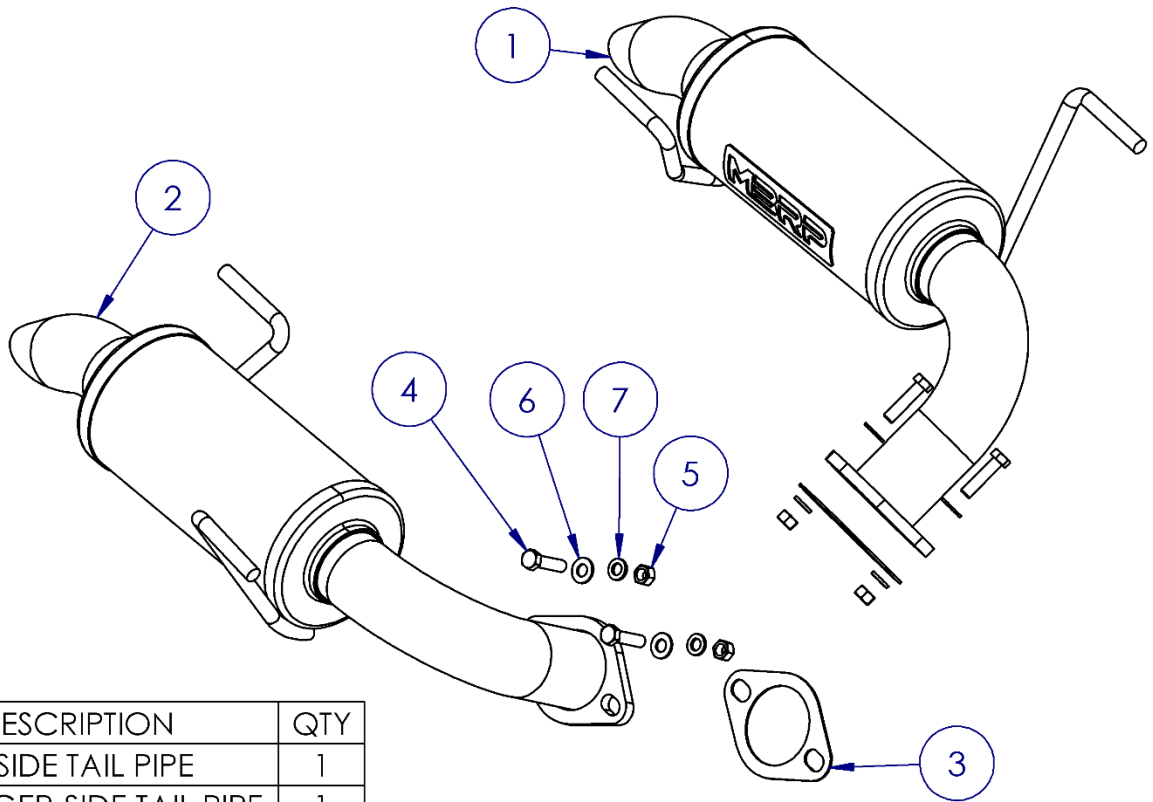

ITEM	DESCRIPTION	QTY
1	DRIVER-SIDE TAIL PIPE	1
2	PASSENGER-SIDE TAIL PIPE	1
3	GASKET	2
4	3/8" X 1.5" HEX BOLT	4
5	3/8" HEX NUT	4
6	3/8" FLAT WASHER	4
7	3/8" LOCK WASHER	4

Refer to this LOT NUMBER when contacting customer service: _____

PLEASE READ BEFORE STARTING INSTALLATION

While MBRP has made every effort to ensure that all components of this system are of superior quality and properly packaged, it is the installer's responsibility to ensure the following before removal of the factory exhaust:

- that ALL components shown above are present.
- that ALL mating components fit together.
- that there are no damaged components.
- that the system you have purchased is appropriate for your vehicle year, model and configuration.
- that the system will not interfere with any modifications previously installed or planned.
- that you have read and understand these instructions.

If you have any questions or are uncertain about any aspect of the installation of this system to your vehicle please contact your dealer before commencing installation.

MBRP

Removal of Stock System



Figure 1

1. Apply penetrating lubricant liberally to all exhaust fasteners, hangers, and rubber insulators.
2. Disconnect the exhaust flanges at the rear of the vehicle and remove the mufflers from the vehicle.
Refer to Figure 1.



Figure 2

3. Remove the round gaskets from the factory exhaust.
Refer to Figure 2.

Installation of MBRP Performance Exhaust



Figure 3

1. Remove the factory insulators from the vehicle and slide onto the **Tail Pipes**.
Refer to Figure 3.
2. Hang the **Tail Pipes** by attaching the insulators to the vehicle.
Refer to Figure 4.



Figure 4

3. With the supplied **Gaskets** mount each **Tail Pipe** to the factory exhaust using the **3/8" Hardware**.
Refer to Figure 5.



Figure 5

4. Carefully align the system. Tighten all hardware, starting at the front and working rearward to secure the system. Check along the full length of the exhaust system to ensure there is adequate clearance for fuel lines, vent lines, brake lines, frame, bodywork, suspension and any wiring, etc. If there is any interference detected, relocate or adjust to provide adequate clearance. Verify clearances, system security and band clamp torque after 30-60 miles (50-100 km) of driving.



Congratulations! You are ready to begin experiencing the improved power, sound and driving experience of your **MBRP** Performance Exhaust. We know you will enjoy your purchase!